



## User Instruction Manual 3511063 (SSB63) Climb Assist/ Fall Arrest System

*This manual is intended to meet the Manufacturer's Instructions as required by ANSI Z359.1, ANSI A10.14, and the Canadian Standards Association, and should be used as part of an employee training program as required by OSHA.*

**WARNING:** This product is part of a personal fall arrest system. The user must read and follow the manufacturer's instructions for each component of the system. These instructions must be provided to the user of this equipment. The user must read and understand these instructions before using this equipment. Manufacturer's instructions must be followed for proper use and maintenance of this equipment. Alterations or misuse of this equipment, or failure to follow instructions, may result in serious injury or death.

**IMPORTANT:** If you have questions on the use, care, application, or suitability of this safety equipment, contact DBI/SALA.

**IMPORTANT:** Before using this equipment, record the product identification information from the ID label in the inspection and maintenance log in section 9.0 of this manual.

### DESCRIPTIONS

**3511063 (SSB63):** Climb Assist/Fall Arrest Safety Block.

**3512000:** Cable Assembly, including the Harness and Rung Hook Assembly (last three (3) numbers are the length of the cable).

**3511783:** Mast Assembly, for round rung ladders up to 3/4-inch diameter or square rungs ladders up to 9/16-inch diameter.

**3511785:** Mast Assembly, for square rung ladders over 9/16-inch diameter up to 1 3/4-inch and round rung ladders over 3/4-inch up to 1 3/8-inch diameter.

**3511598:** Counterweight with Brake Lever Assembly.

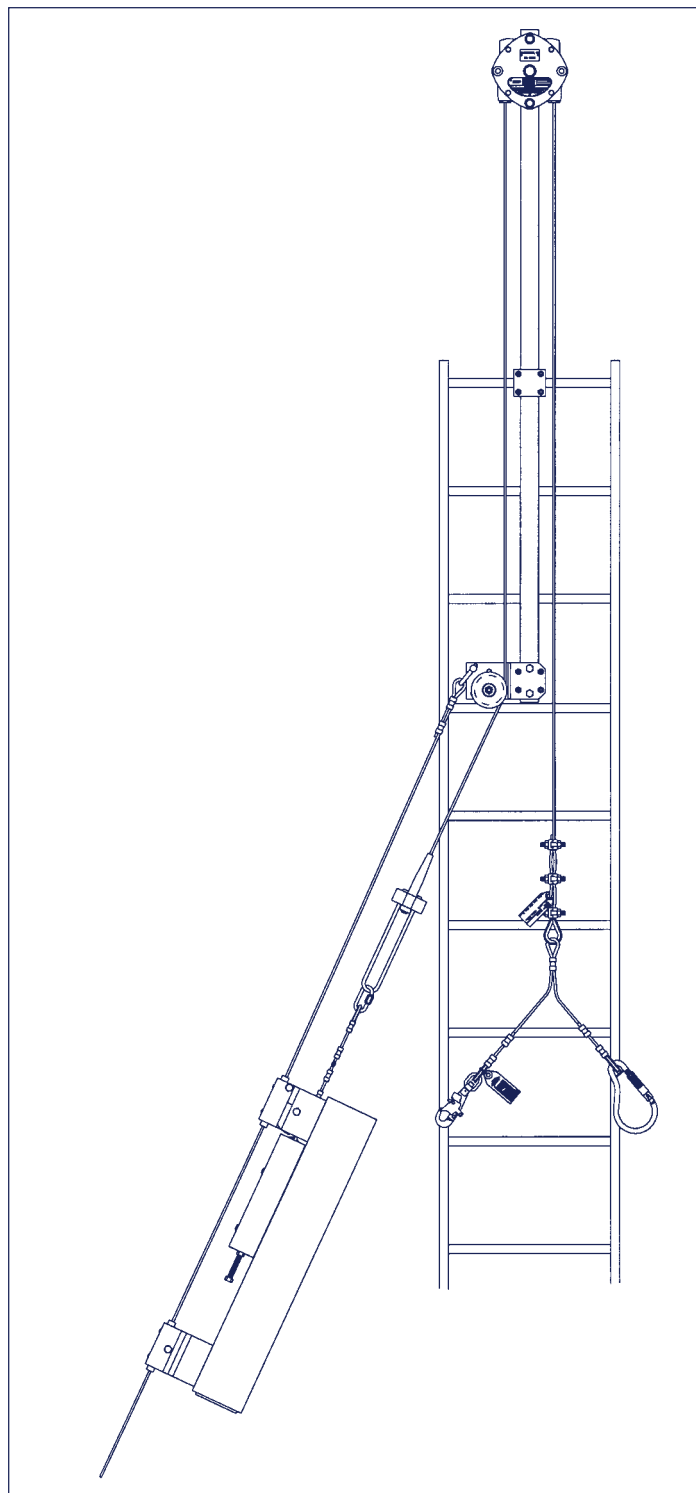

Figure 1 - 3511063 (SSB63 Safety Block) and Cable Assembly

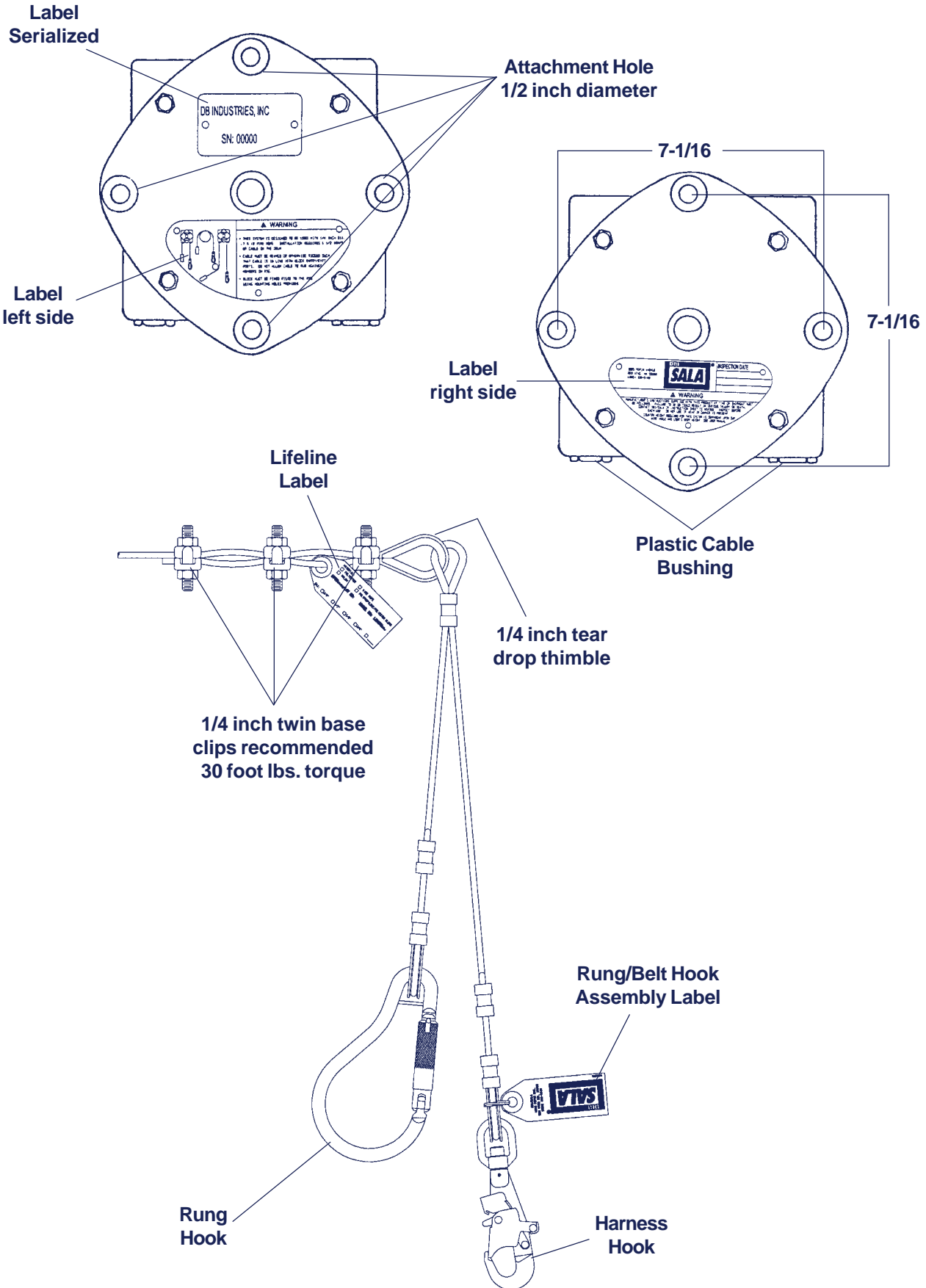
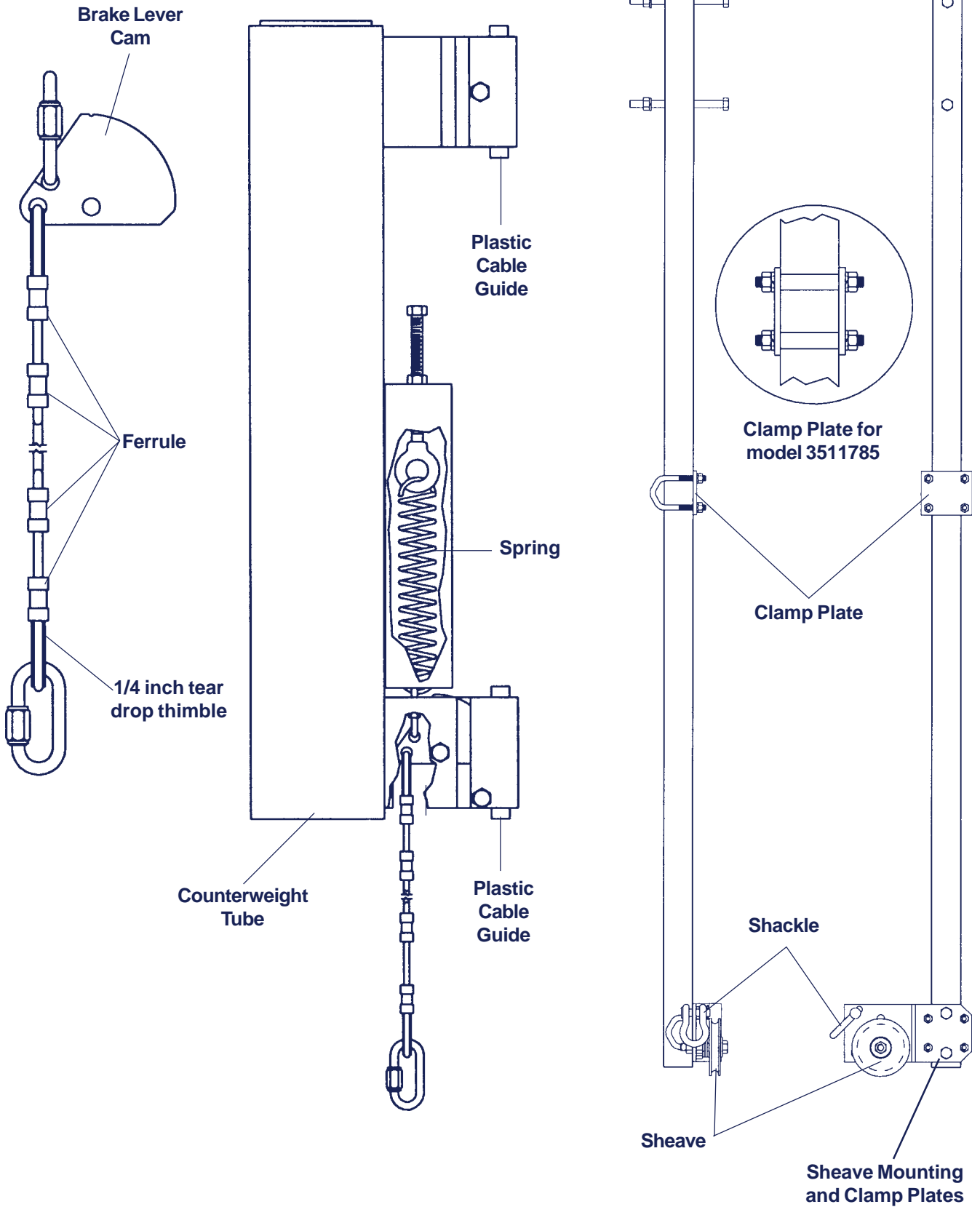

Figure 2 - Mast Assembly (Model 3511783 shown)



## 1.0 APPLICATIONS

**1.1 PURPOSE:** The DBI/SALA Climb Assist/Fall Arrest System is a component used in a personal fall arrest system (PFAS). This equipment is to be used in situations where worker mobility and fall protection is needed (inspection work, general construction, maintenance work, oil production, confined space work, etc.). The DBI/SALA Climb Assist/Fall Arrest System can also provide assistance in climbing fixed ladders.

**A. FALL ARREST:** This equipment is used as part of a complete fall arrest system. Such systems typically include a full body harness, anchorage connector (i.e. carabiner) and the Climb Assist/Fall Arrest System. This type of system is used where a fall hazard exists.

**1.2 LIMITATIONS:** The following application limitations must be considered before using this product:

**A. CORROSION:** Do not leave this equipment for long periods in environments where corrosion of metal parts could take place as a result of vapors from organic materials. Use caution when working around sewage or fertilizer because of their high concentration of ammonia, which is very corrosive. Use near seawater or other corrosive environments may require more frequent inspections or servicing to ensure corrosion damage is not affecting the performance of the product.

**B. CHEMICAL HAZARDS:** Solutions containing acid or caustic chemicals, particularly at elevated temperatures, may damage DBI/SALA Climb Assist/Fall Arrest System's. When working with such chemicals, frequent inspection of the entire system must be completed. Chemical damage to the lifeline is difficult to detect and it is recommended that the lifeline be replaced periodically to ensure safety. Consult DBI/SALA if in doubt about using this equipment around chemical hazards.

**C. HEAT:** This equipment is not designed for use in high temperature environments. Provide protection for this equipment when using near welding, metal cutting, or similar activities. Hot sparks may burn or damage this equipment. Contact DBI/SALA for details on use of this equipment in high temperature environments.

**D. ELECTRICAL HAZARDS:** There is a possibility of electric current flowing through the lifeline. Use caution where the lifeline may contact high voltage power lines.

**E. CAPACITY:** The Climb Assist/Fall Arrest System is for use by persons with a combined weight (person, clothing, tools, etc.) of 75 lbs. minimum and 310 lbs. maximum. No more than one person can connect to an Climb Assist/Fall Arrest System for fall arrest applications.

**F. LOCKING SPEED:** Situations which do not allow for an unobstructed fall path should be avoided. Working in confined or cramped spaces may not allow sufficient speed to cause the system to lock in a fall. A clear path is required to ensure positive locking of the system.

**G. NORMAL OPERATION:** Normal operation will allow the full length of the lifeline to extend and retract as the worker moves. If a fall occurs, the locking pawls will engage into the grooves (or teeth), stopping the fall (Figure 3). The cable will slide on the drum a limited distance to absorb much of the energy created in the fall. If a fall has been arrested, the Climb Assist/Fall Arrest System must be taken out of service and inspected. See section 5.0. Sudden or quick movements should be avoided during the normal work operation, as this may cause the system to lock-up.

**H. TRAINING:** This equipment must be installed and used by persons trained in its correct application and use.

**I. USE OF COUNTERWEIGHT:** The climb Assist/Fall Arrest System must be used in conjunction with a counterweight to maintain a taught cable. Do not use this system with out a counterweight.

**1.3** Refer to national standards, including ANSI Z359.1 and ANSI A10.14, and applicable local, state, and federal (OSHA) requirements governing this equipment for more information on personal fall arrest systems and associated system components.

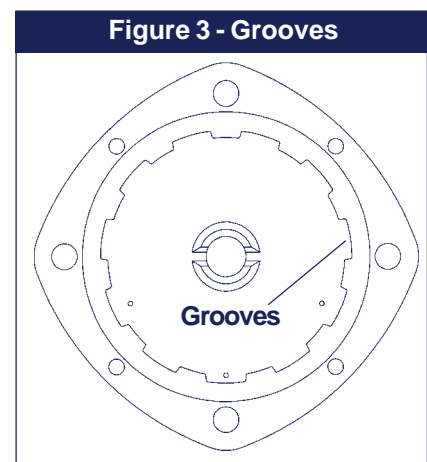

## 2.0 SYSTEM REQUIREMENTS

**2.1 COMPATIBILITY OF COMPONENTS:** DBI/SALA equipment is designed for use with DBI/SALA approved components and subsystems only. Substitutions or replacements made with non-approved components or subsystems may jeopardize compatibility of equipment and may affect the safety and reliability of the complete system.

**2.2 COMPATIBILITY OF CONNECTORS:** Connectors are considered to be compatible with connecting elements when they have been designed to work together in such a way that their sizes and shapes do not cause their gate mechanisms to inadvertently open regardless of how they become oriented. Contact DBI/SALA if you have any questions about compatibility.

Connectors (hooks, carabiners, and D-rings) must be capable of supporting at least 5,000 lbs. (22.2kN). Connectors must be compatible with the anchorage or other system components. Do not use equipment that is not compatible. Non-compatible connectors may unintentionally disengage. See Figure 4. Connectors must be compatible in size, shape, and strength. Self locking snap hooks and carabiners are required by ANSI Z359.1 and OSHA, and in Canada, by CSA Z259.12.

**Figure 4 - Unintentional Disengagement (Roll-out)**

If the connecting element that a snap hook (shown) or carabiner attaches to is undersized or irregular in shape, a situation could occur where the connecting element applies a force to the gate of the snap hook or carabiner. This force may cause the gate (of either a self-locking or a non-locking snap hook) to open, allowing the snap hook or carabiner to disengage from the connecting point.

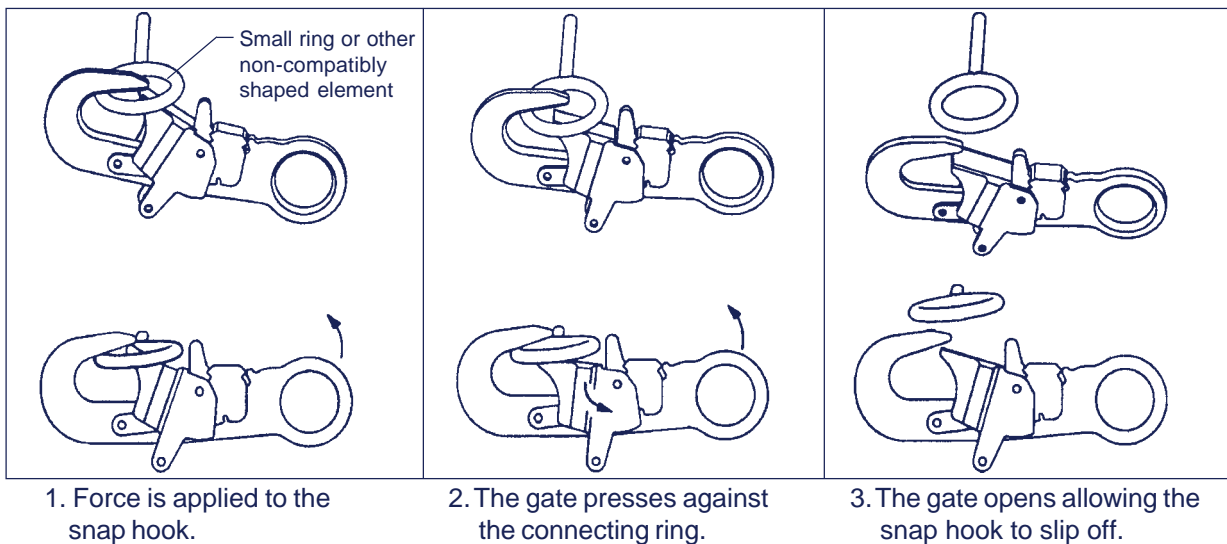

**2.3 MAKING CONNECTIONS:** Only use self-locking snap hooks and carabiners with this equipment. Only use connectors that are suitable to each application. Ensure all connections are compatible in size, shape and strength. Do not use equipment that is not compatible. Ensure all connectors are fully closed and locked.

DBI/SALA connectors (snap hooks and carabiners) are designed to be used only as specified in each product's user's instructions. See Figure 5 for inappropriate connections. DBI/SALA snap hooks and carabiners should not be connected:

- A. To a D-ring to which another connector is attached.
- B. In a manner that would result in a load on the gate.

**NOTE:** Large throat opening snap hooks should not be connected to standard size D-rings or similar objects which will result in a load on the gate if the hook or D-ring twists or rotates. Large throat snap hooks are designed for use on fixed structural elements such as rebar or cross members that are not shaped in a way that can capture the gate of the hook.

- C. In a false engagement, where features that protrude from the snap hook or carabiner catch on the anchor and without visual confirmation seems to be fully engaged to the anchor point.

- D. To each other.
- E. Directly to webbing or rope lanyard or tie-back (unless the manufacturer's instructions for both the lanyard and connector specifically allow such a connection).
- F. To any object which is shaped or dimensioned such that the snap hook or carabiner will not close and lock, or that roll-out could occur.

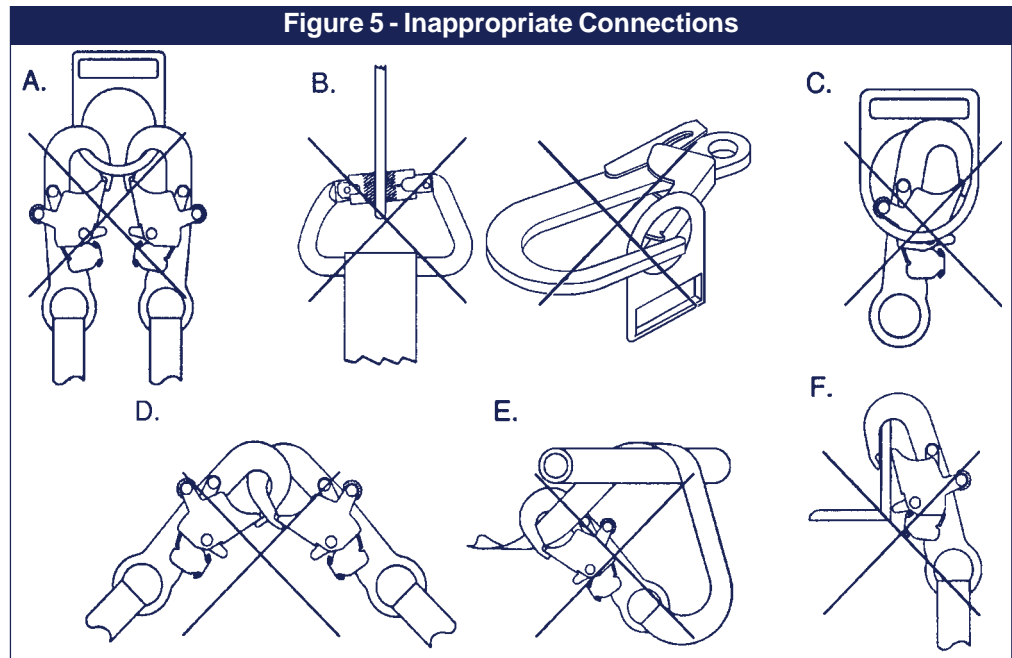

### 3.0 INSTALLATION AND USE

**WARNING:** Do not alter or intentionally misuse this equipment. Consult DBI/SALA when using this equipment in combination with components or subsystems other than those described in this manual. Some subsystem and component combinations may interfere with the operation of this equipment. Use caution when using this equipment around moving machinery, electrical and chemical hazards, and sharp edges.

**WARNING:** Consult your doctor if there is reason to doubt your fitness to safely absorb the shock from a fall arrest. Age and fitness seriously affect a worker's ability to withstand falls. Pregnant women or minors must not use the DBI/SALA Climb Assist/Fall Arrest System.

- 3.1 **BEFORE EACH USE** of this equipment, carefully inspect it according to steps listed in section 5.0.
- 3.2 **PLANNING:** Plan your fall protection system and how it will be used before starting your work. Consider all factors that will affect your safety before, during, and after a fall. The following list gives some important points to consider when planning your system:
  - A. **ANCHORAGE:** Select a rigid anchorage point that is capable of supporting 5,000 lbs. (22.2kN). The anchorage location must be carefully selected to reduce free fall and swing fall hazards, and to avoid striking an object during a fall. Do not work above your anchorage level to avoid an increased free fall distance.
  - B. **FREE FALL:** Personal fall arrest systems must be rigged so the potential free fall is never greater than six feet (five feet per ANSI A10.14). Avoid working above the anchorage level to avoid an increased free fall distance. Avoid working where your line may cross or tangle with that of another worker or object. Do not allow the lifeline to pass under arms or between legs. Do not lengthen the Climb Assist/Fall Arrest System by connecting a lanyard or other components without consulting DBI/SALA.
  - C. **SWING FALLS:** Swing falls occur when the anchorage point is not directly above the point where a fall occurs. The force of striking an object in a swing fall may cause serious injury. In a swing fall, the total vertical fall distance will be greater than if the user had fallen directly below the anchorage point, thus increasing the total free fall distance and the area required to safely arrest the user. In order to minimize wear and friction between the lifeline and the cable bushing on the housing and to decrease swing fall hazards, DBI/SALA recommends your work zone be within 5° of the anchorage point. Minimize swing falls by working as directly below the anchorage point as possible. Never permit a swing fall if injury could occur. If a swing fall situation exists in your application contact DBI/SALA before proceeding.
  - D. **FALL CLEARANCE:** Ensure adequate clearance exists in your fall path to prevent striking an object. A minimum of six feet from the working level to the lower level or nearest obstruction is recommended.

- E. **SHARP EDGES:** Avoid working where the lifeline will be in contact with, or abrade against sharp edges. Provide protection for the lifeline when possible.
- F. **RESCUE:** If a fall occurs, the employer must have a rescue plan and the ability to implement a rescue.
- G. **AFTER A FALL:** Equipment which has been subjected to fall arrest forces must be removed from service for inspection. See section 5.0.

**WARNING:** Read and follow manufacturer's instructions for associated equipment (i.e. full body harness) used in your personal fall arrest system.

**3.3 BODY SUPPORT:** When using DBI/SALA Climb Assist/Fall Arrest System, a full body harness must be worn. For general fall protection use, connect to the back D-ring. For situations such as ladder climbing, attach to the front D-ring of the harness. This is acceptable provided the potential free fall is very short, and footing can be easily regained.

**IMPORTANT:** Do not use a body belt for free fall applications. See OSHA 1926.502 for guidelines.

### 3.4 INSTALLATION:

**A. Wire Rope Installation:** The correct wire rope for the Climb Assist/Fall Arrest System is 1/4-inch diameter, right hand lay, 7x19 galvanized aircraft cable (do not substitute other cable constructions or material). The length of cable will depend on the location of the safety block, its height off the ground, and the location of the guy cable. A general rule is to take the distance from where the climb starts to the location of the safety block, plus the distance from the safety block to the top of the guy line and counterweight position (see Figures 10 and 13).

- Step 1.** Lay the safety block on a clean work surface and remove the four (4) cover bolts; then pry the cover off. Using caution not to damage the springs, lift ratchet pawls off of drum. Carefully remove the spring from the screw head and set aside (Figure 6). Lift the drum from the housing and remove the pawls and spring from the opposite side. Feed approximately three feet of wire rope through the left hand port (Figure 7).

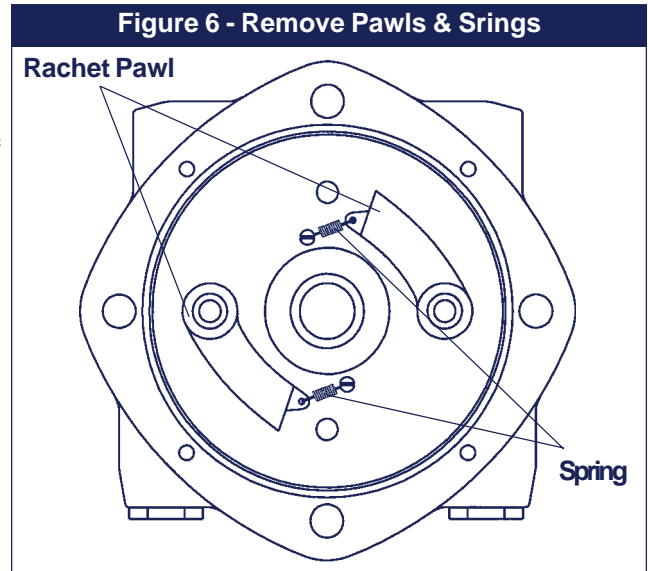

**IMPORTANT:** You must remove the pawl first to assure the spring is not over extended while removing it from the screw head.

- Step 2.** Wrap wire rope clockwise around drum 1-1/2 times, **in a manner which does not allow cable to cross over the previous wrap. The cable must not lap over existing wrap.** Coil the rope upward on the drum. Feed the end of the wire rope through the right port keeping the rope snug on the drum (Figure 8).
- Step 3.** Replace the drum and rotate the shaft until it seats in the cover. Attach the spring around the screw head and replace ratchet pawls. The pawls are stamped with "A" on one side and "B" on the other. Make sure the pawls are replaced with the "A" showing. Pawls should move freely. Replace the cover and tighten the bolts.
- Step 4.** Turn block over and remove the cover. Attach the spring around the screw head and replace ratchet pawls making sure the "A" is showing. Pawls should move freely. Replace cover and tighten bolts.

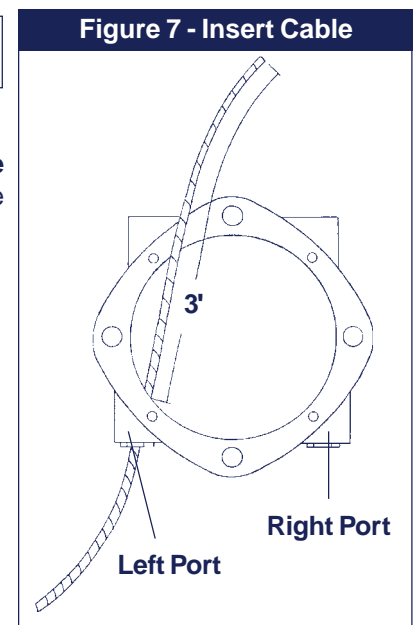

**Step 5.** Put a clamp on the end of the cable to prevent it from pulling out of the block. Mount the block vertically and check the locking action of the block in both directions by applying tension on both ends of the cable end and jerking quickly on one side and vice versa. Repeat step 1-5 if locking action is not satisfactory.

**Step 6.** Connect harness and rung hook assembly to the end of the wire rope that will be run down the climbing surface. Use a minimum of three twin-base wire rope clips and a 1/4-inch thimble to attach harness and rung hook assembly (Figure 9). Make sure clamps are spaced correctly (3 3/4-inch apart) and torqued to 30 foot lbs.

**B. Mounting Safety Block:** Using the attachment holes, mount the block vertically assuring that the attachment point is capable of supporting at least 5,000 lbs. (22.2kN). The block must be mounted rigid and not allowed to pivot or swing. At least two (2) attachment holes must be used.

The wire rope must enter and exit the safety block as closely in-line with the wire rope ports as possible. This may be accomplished by using sheaves to direct the wire rope to the desired location. Sheaves designed for use with 1/4-inch diameter wire rope must be used (see Figure 9).

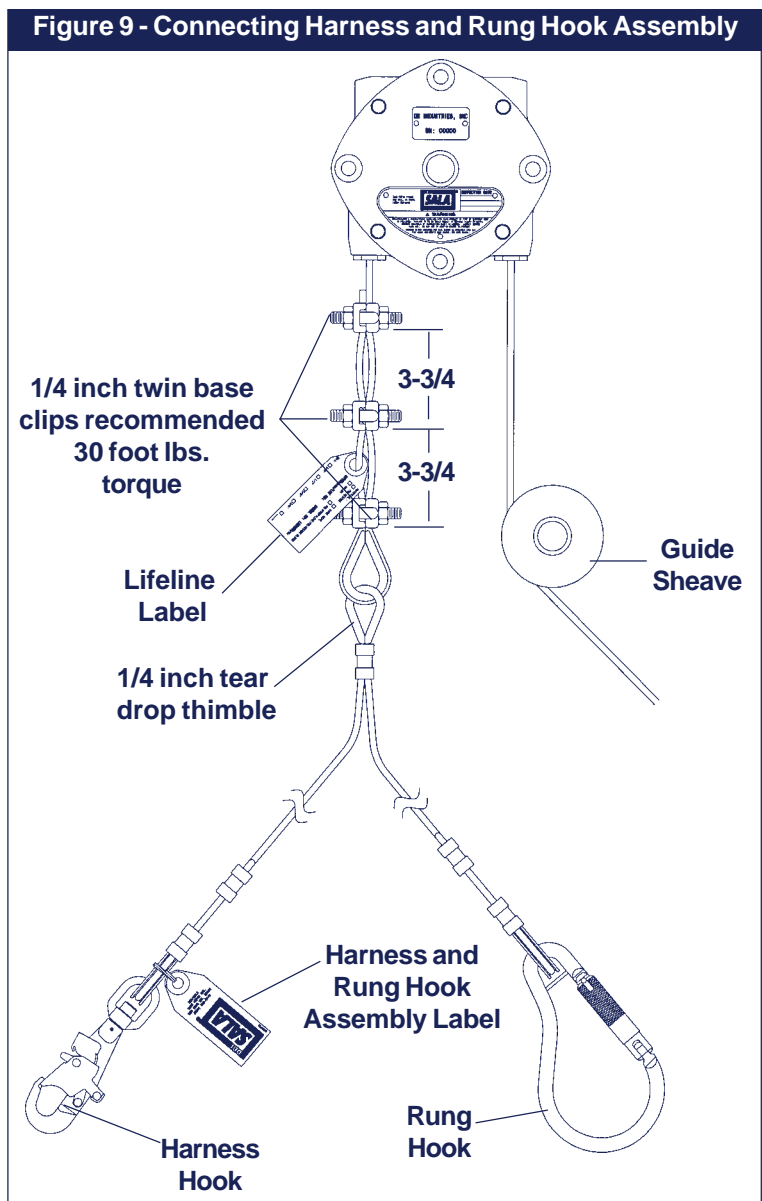

The use of a climb assist mast for ease of mounting and operation is recommended. The climb assist mast must not extend above the last ladder connection by more than four (4) feet. Select the correct mast based on the size of ladder rungs you plan on attaching the mast to (Figures 10 and 11). Secure mast to ladder using attachment hardware provided with the mast. Mast must be secured to ladder structure using at least two (2) rung clamp assemblies (Figures 10 and 11). Position mast on ladder as directly above climbing area as possible. Consider guy wire location when positioning mast. Torque fasteners to 20-25 foot lbs. The bottom plate on the mast can be reversed to allow the counterweight to operate on either side. See Figure 11.

**NOTE:** Some applications may require an alternative mounting method for the climb assist mast. For example, the mast may be mounted to the side rails of a ladder or to a structure other than the ladder. All mountings shall be capable of supporting the loads specified in section 3.2.

**C. Counterweight Installation:** The DBI/SALA counterweight weighs 80 pounds empty, and additional weight can be placed inside the weight tube up to 170 lbs. See table in Figure 12 for specifics. Do not hang weight outside the tube. Do not exceed maximum allowable counterweight.

The DBI/SALA counterweight includes a locking cam designed to arrest the counterweight should it fall for any reason. The counterweight locking cam is designed to operate on 1/2-inch diameter guy cable. The angle the guy cable makes with the ground must be between 45° and 75° as shown in Figure 12. The guy cable should be anchored to the ground structure. The anchor point should support 1,000 lbs. minimum. When the

Figure 10 - Connecting Climb Assist Mast

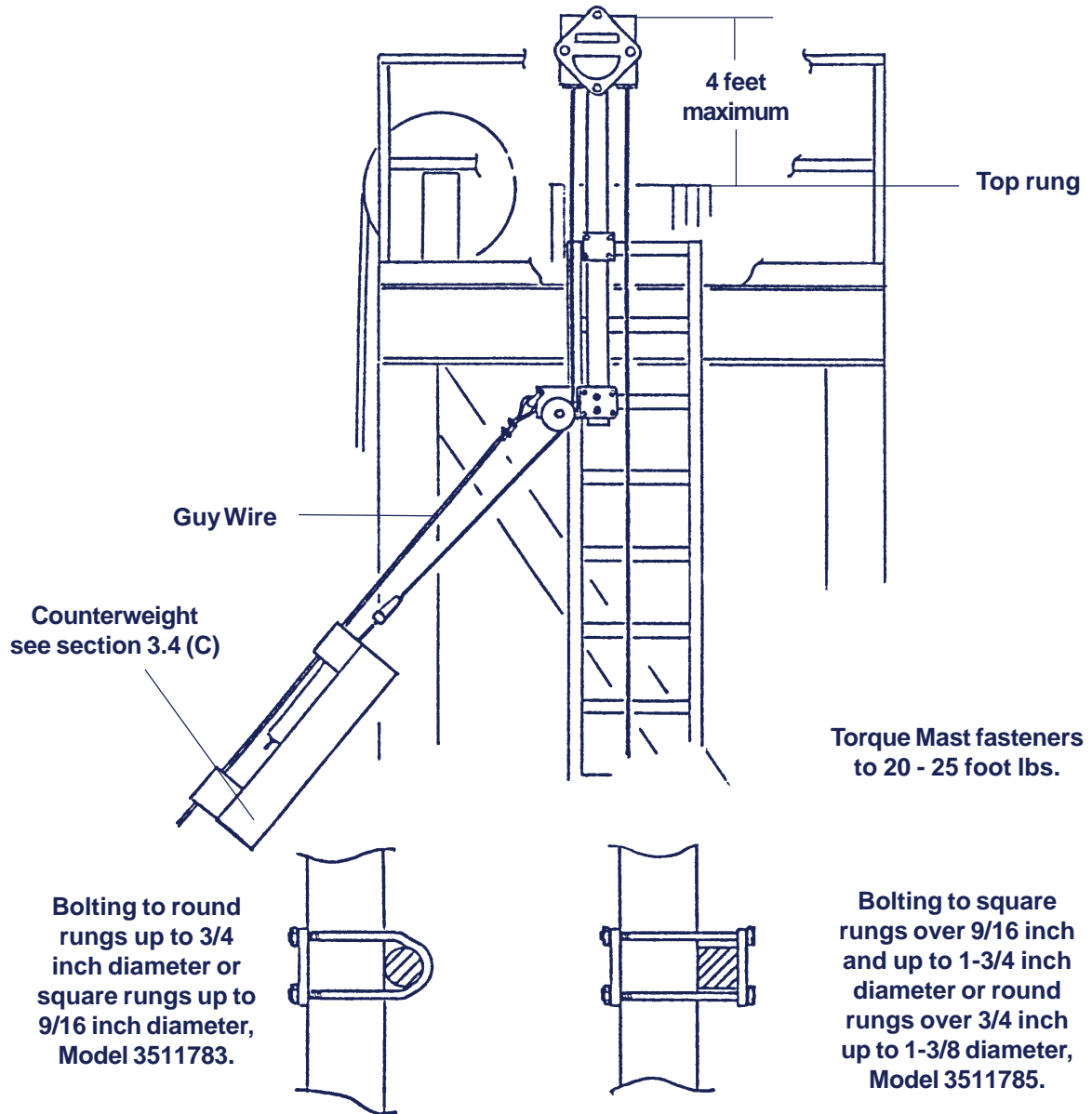

climb assist mast is used, the guy cable should be attached to the shackle located above the sheave on the bottom of the mast. Use cable clips or similar items to attach guy cable to shackle. See Figure 13 for approximate guy cable length based on angle of installation.

**IMPORTANT:** The Climb Assist/Fall Arrest requires the use of a counterweight to provide cable tension in the locking drum.

**NOTE:** The recommended angle the guy cable makes with the ground is 60°. Figure 13 details the correct set up based on a 60° angle.

- Step 1.** Loosen spring tension by threading tension adjusting nut up to the anchor nut. Remove cable retaining bolts from ends of counterweight (Figure 12).
- Step 2.** Lift counterweight up to the 1/2-inch guy cable and slide guy cable through grooves at each end of the counterweight. Make sure the guy cable rests in the slots of plastic cable guide wear strip. Replace cable retaining bolts. Tighten tension adjusting nut until there is **3 inches of exposed thread** between the two (2) nuts (Figure 12).

Figure 11 - Connecting Climb Assist Mast

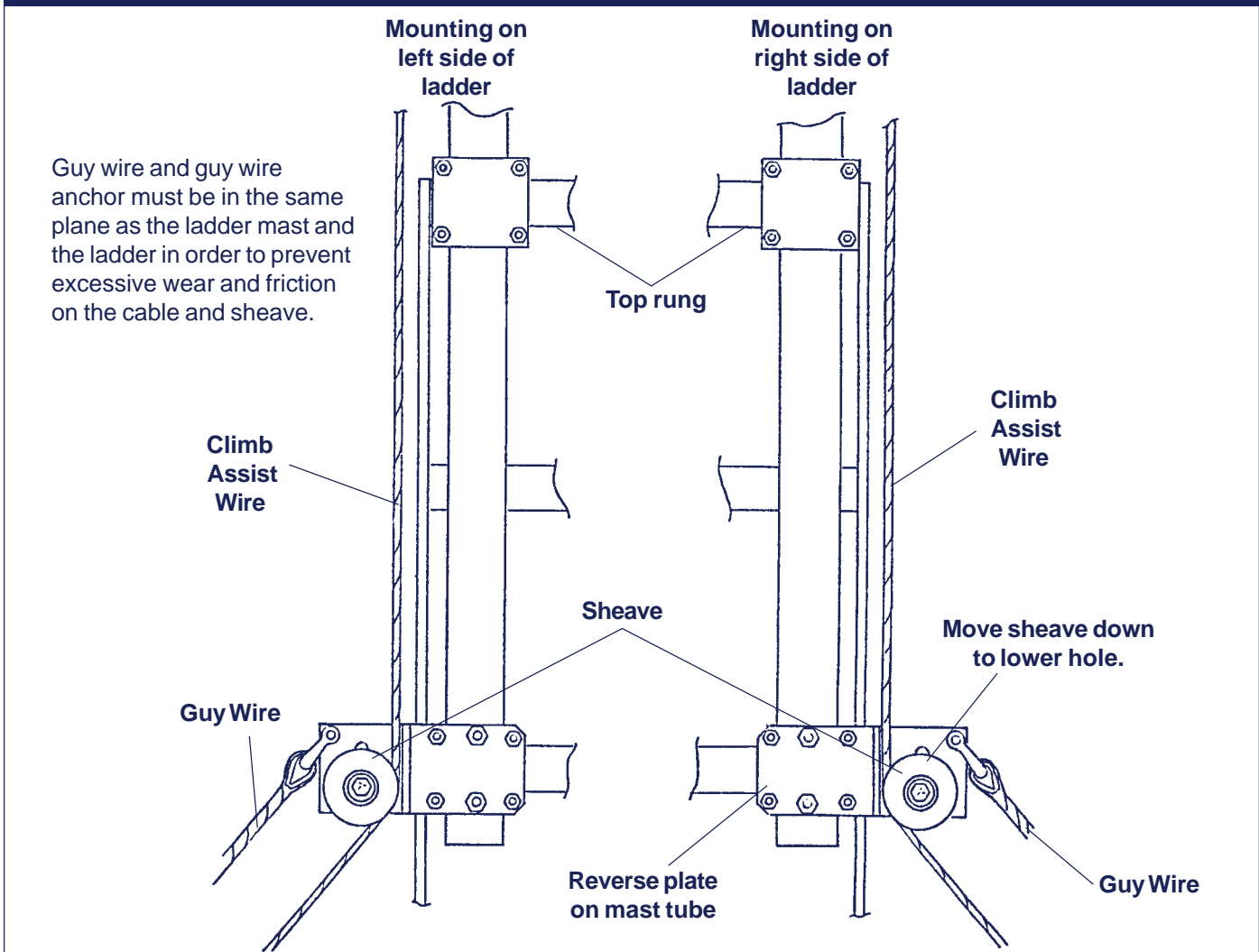

**Step 3.** Secure 1/4-inch cable from the Climb Assist/Fall Arrest System to the counterweight quick link. Use a 1/4-inch thimble and three (3) twin base clamps. Space between clamps must be 3 3/4-inch. At least 1/2-inch of cable must extend past the last clamp. Torque clamps to 30 foot lbs. (Figure 12).

**NOTE:** The tension in the spring may be too tight to allow the counterweight to go down if the guy wire is not steep enough, and or little additional weight is added to the empty counterweight. If this should happen make the following adjustments:

With the counterweight loaded to the weight you anticipate using, loosen the tension adjusting nut two (2) complete turns and try the climb assist device to see if the counterweight slides down the guy wire as the climber climbs the ladder. The adjustment procedure can be continued until the counterweight moves freely down the guy wire. **DO NOT** loosen the tension adjusting nut further than two (2) turns past the point at which the counterweight can move freely down the guy wire. If the guy wire angle changes for any reason, the tension adjusting nut must be reset as described previously.

**3.5 OPERATION:** Inspect the Climb Assist/Fall Arrest System as described in section 5.0. Attach harness connecting hook to dorsal (back D-ring) of DBI/SALA full body harness or to front D-ring for ladder climbing. Connect the rung hook to side D-ring of harness or around strap of harness to prevent entanglement. The harness connecting hook line must be taut when ascending and descending. When attaching to the system do not let go of the harness and rung hook assembly until the snap hook is securely attached to the appropriate D-ring on the user's harness.

Once the worker's PFAS is connected, ascending and descending can take place. Climb at normal work pace. Counterweight will assist in the climbing effort; counterweight must not pull climber up the structure. If this occurs, the counterweight is too heavy. Cable must remain taut at all times. Before disconnecting from the system, attach rung hook to structure to prevent the harness/rung assembly from traveling up the ladder when released.

Figure 12 - Counterweight Installation

Secure 1/4 inch cable from safety block to counterweight quick link using 1/4 inch twin base clips and thimble. Assemble same as shown in Figure 8. Torque clamps to 30 foot lbs.

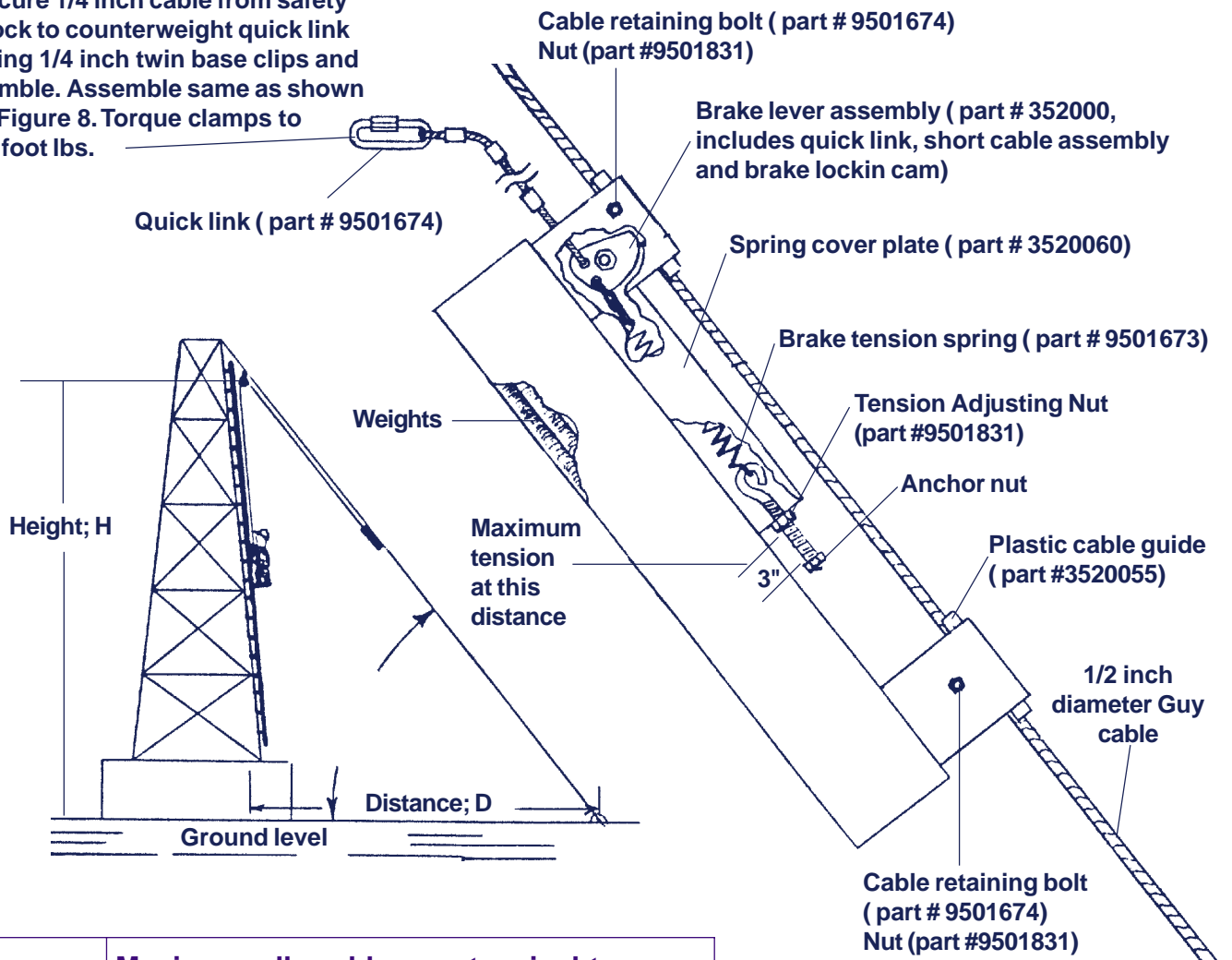

		Maximum allowable counterweight						
Worker weight (lbs.)	Guy Cable Angle							
	45°	50°	55°	60°	65°	70°	75°	
130	110	102	95	90	86	83	80	
140	119	110	103	97	93	89	87	
150	127	117	110	104	99	96	93	
160	136	125	117	111	106	102	99	
170	144	133	125	118	113	108	106	
180	153	141	132	125	119	115	112	
190	161	149	139	132	125	121	118	
200	170	157	146	139	132	128	124	
•	•	•	•	•	•	•	•	
•	•	•	•	•	•	•	•	
•	•	•	•	•	•	•	•	
300	170	157	146	139	132	128	124	

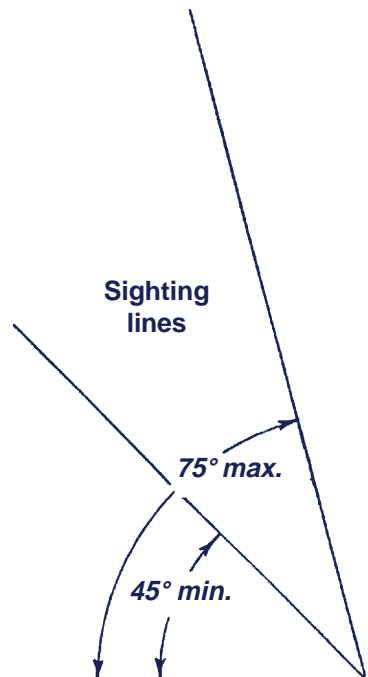

**NOTE:** Weight of the counterweight is 80 lbs. The recommended weights are 7/8-inch diameter round steel bars 36 inches long, 6 lbs. each. For steeper guy cable angles consult DBI/SALA.

**Figure 13 - Guy Wire Installation and Positioning**

Approximate Amount of Guy Cable Needed* ("C" ft.)			
Vertical Distance from ground to Guy Cable Connection "H" ft.	"B" Guy Cable Angle to ground is:		
	45°	60°	75°
40	57	46	41
50	71	58	52
60	85	69	62
70	99	81	72
80	113	92	83
90	127	104	93
100	141	115	103
110	156	127	114
120	170	138	124

\*Amount of guy cable needed does not take into account sag in guy cable. Additional cable will be needed to allow for sag.

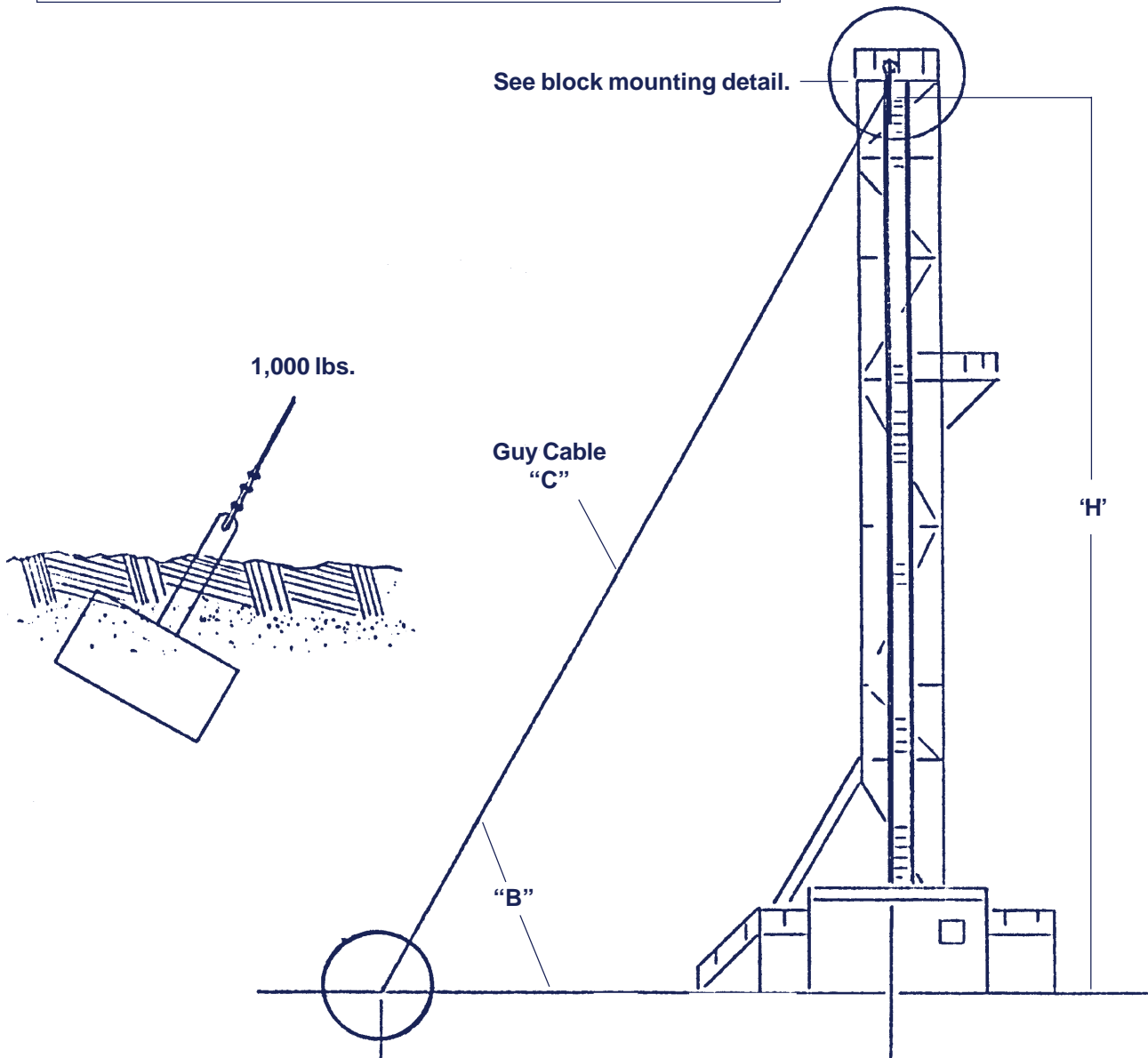

**NOTE:** Use 1/2 inch diameter wire rope. Guy should be installed with a minimum of cable sag.

**3.6 USE:** When attached to the Climb Assist/Fall Arrest System, the worker is free to move about within recommended working areas at normal speeds. Should a fall occur, the Climb Assist/Fall arrest System will lock and arrest the fall. The system will also assist the climber when ascending.

## **4.0 TRAINING**

**4.1** It is the responsibility of the user and the purchaser of this equipment to assure that they are familiar with these instructions, trained in the correct care and use of, and are aware of the operating characteristics, application limits, and the consequences of improper use of this equipment.

**IMPORTANT:** Training must be conducted without exposing the trainee to a fall hazard. Training should be repeated on a periodic basis.

## **5.0 INSPECTION**

### **5.1 FREQUENCY:**

- **Before Each Use:** Inspect according to steps listed in sections 5.2, 5.3, and 5.4.
- **Monthly:** A formal inspection of the entire Climb Assist/Fall Arrest System should be completed by a competent person other than the user. See sections 5.2 and 5.3 for guidelines. Record results in the inspection and maintenance log in section 9.0.
- **Every Two Years:** DBI/SALA Climb Assist/Fall Arrest System are required to be serviced at least every two years. Servicing can be performed by an authorized service center or by the end user per the instructions in section 5.0 and 6.0. Extreme working conditions may require increasing service frequency. Contact DBI/SALA for service frequencies in extreme working conditions. Service shall include, but not be limited to, an intensive inspection and cleaning of all components. Failure to provide required service may shorten the product life and endanger performance. A record of service dates can be found on the ID label on the face of the safety block. See Figure 1 and section 8.0.
- **After a Fall Arrest:** Remove the entire system from service. A competent person shall inspect the block unit, counterweight and climb assist mast per section 5.0 and 6.0. The cable assembly and harness and rung hook assembly shall be replaced.

**WARNING:** If the Climb Assist/Fall Arrest System has been subjected to fall arrest or impact forces, it must be removed from service and inspected according to sections 5.2 and 5.3.

**IMPORTANT:** Extreme working conditions (harsh environment, prolonged use, etc.) may require increasing the frequency of inspections.

### **5.2 INSPECTION STEPS:**

- Step 1.** Remove the four cover bolts and washers. Lift drum from housing and inspect the pawls and springs; pawls should be undamaged and move freely on pivot stud. Check springs for tightness.
- Step 2.** Inspect drum face; heavy grooves indicate need for replacement. Inspect drum bushings; excessive play between bushing and shaft indicate replacement is needed. (Part numbers for Safety Block can be found on page 17.)
- Step 3.** Clean and reassemble block; lubricate locking pawl pivot point with a good quality, low temperature silicone grease. Check that all fasteners are in place and tight. See section 3.4 (A) for block assembly.
- Step 4.** Ensure the device locks up when lifeline is jerked sharply. Lock-up must be positive, with no slipping.
- Step 5.** The labels must be present and fully legible. See section 8.0
- Step 6.** Look for signs of corrosion on the entire unit.

- Step 7.** Inspect lifeline. Look for cuts, kinks, burns, broken wires or strands, chemical damage, and severe abrasion. The lifeline must not be damaged.
- Step 8.** Inspect connecting hooks and carabiners for signs of damage, corrosion and working condition. **Check wire rope clips for tightness.**
- Step 9.** Inspect the mast. Check for corrosion damage. Check all nuts and bolts for tightness. Check pulleys for operation.
- Step 10.** Inspect counterweight and guy wire. Check locking action of counterweight. Check surface of brake lever; replace if grooves are worn in over “WEAR MARK” on brake lever as shown in Figure 12. When replacing brake lever, the plastic cable guide must also be replaced (part numbers can be found in Figure 12).
- Step 11.** Inspect each system component or subsystem per associated manufacturer’s instructions.
- Step 12.** Record inspection results in inspection and maintenance log in section 9.0.

**5.3** If inspection or operation reveals a defective condition, remove from service and repair or contact an authorized service center.

**WARNING:** The components of this system are designed for compatibility; alterations or substitutions in any part of this system shall not be allowed.

## 6.0 MAINTENANCE, SERVICING, STORAGE

**6.1** Periodically clean the exterior of the Safety Block with water and mild soap solution. Position the Safety Block so excess water can drain out. Clean labels as required.

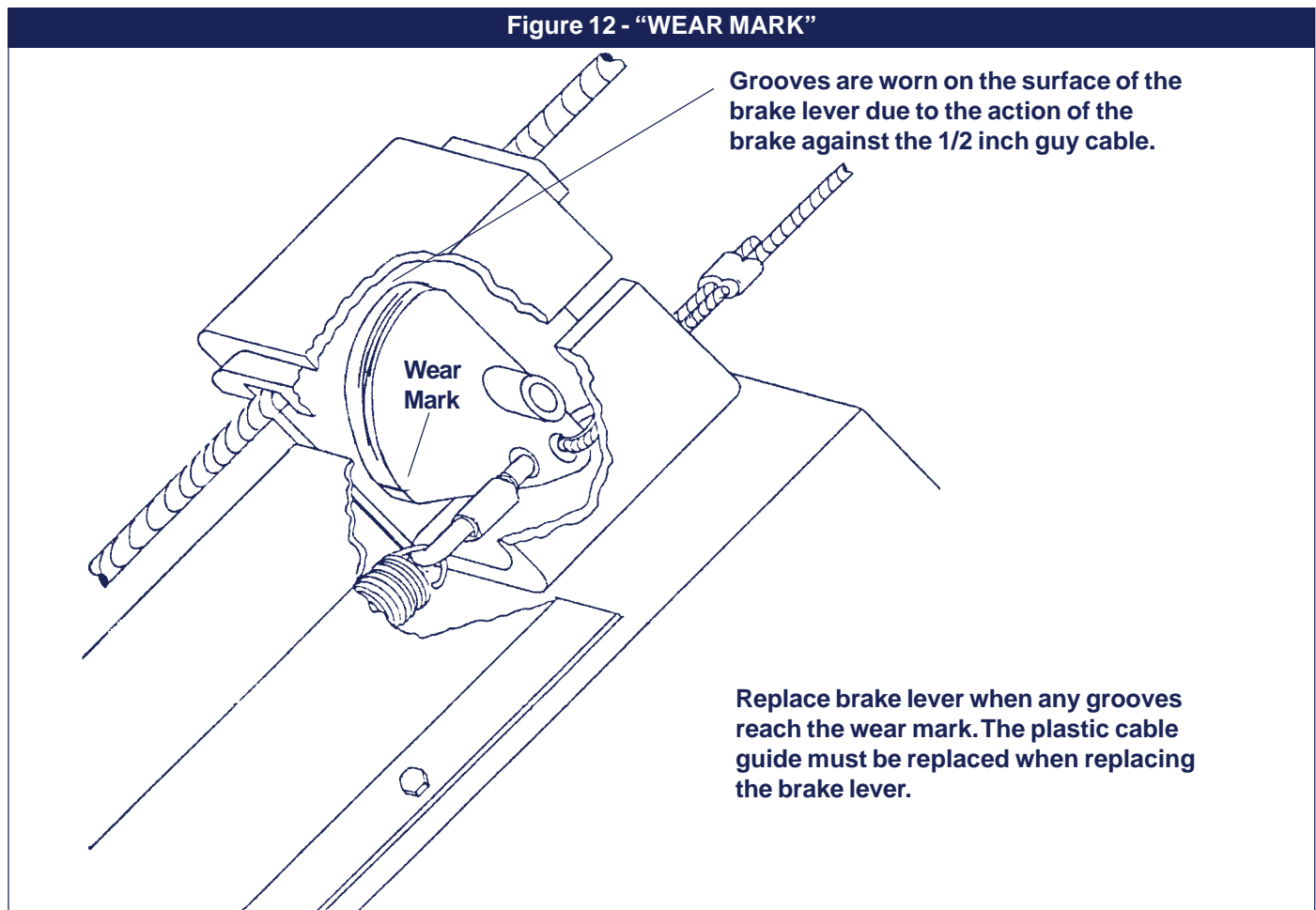

- 6.2 Clean lifeline with water and mild soap solution. Rinse and thoroughly air dry. Do not force dry with heat. An excessive buildup of dirt, paint, etc., may prevent the lifeline from retracting freely, causing a potential free fall hazard. Replace the lifeline if there is excessive buildup.

**WARNING:** *If the lifeline contacts acids, remove unit from service and wash with water and mild soap solution. Inspect unit before returning to service.*

- 6.3 Lubricate the pawl pivot points and the counterweight locking cam with a good quality, low temperature silicone grease.
- 6.4 Clean and store body support and associated system components according to manufacturer's instructions.
- 6.5 Store in a cool, dry, clean environment, out of direct sunlight. Avoid areas where chemical vapors may exist. Inspect the system after extended storage.

## 7.0 **SPECIFICATIONS**

As a system, complies with ANSI A10.14 and OSHA requirements.  
Average locking speed of Safety Block: 4.5 ft./sec.

### **MATERIAL;**

#### **Safety Block**

Housing: Aluminum, Alloy  
Cover: Aluminum, Alloy  
Pawl: Stainless Steel  
Drum: Steel, Plated  
Shaft: Steel, Plated  
Bearing: Bronze

#### **Cable Assembly with Harness and Rung Hook Assembly**

Cable: 1/4 inch, 7x19 Galvanized Aircraft, 7000 lbs.  
Carabiner: 1 3/16-in. throat, High Tensile Alloy Steel  
          2 3/16-in. throat, High Tensile Alloy Steel  
Snap Hook: Self locking, Alloy Steel  
Ferrules: 1/4 inch, Aluminum Duplex  
Thimble: 1/4 inch, TD, Galvanized  
Cable Clip: 1/4 inch, Twin Base, Galvanized

#### **Mast Assembly**

Clamp Plate: Galvanized  
Tube Mast: Galvanized  
Sheave Mounting: Galvanized  
Shackle: 7/16 inch, Galvanized  
Sheave: 3/8 inch, Power Metal

#### **Counterweight**

Cable Clip: 1/4 inch, Galvanized  
Thimble: 1/4 inch, TD, Galvanized  
Cable Guide: Plastic  
Tension Spring Cover: Galvanized

#### **Counterweight Brake Lever Assembly**

Cable: 1/4 inch, 7x19 galvanized. 3 feet long  
Ferrule: 1/4 inch, Aluminum Duplex  
Thimble: 1/4 inch, TD, Galvanized  
Quick Link: 3/8 inch, ZP, 7/16-inch opening  
Brake Lever: Brass

## 8.0 LABELING

8.1 The following labels must be present and fully legible:

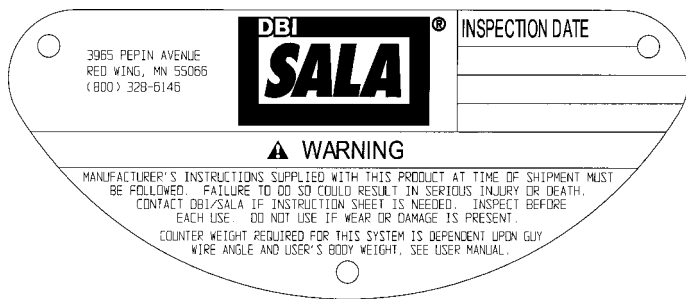

Label - Left Side

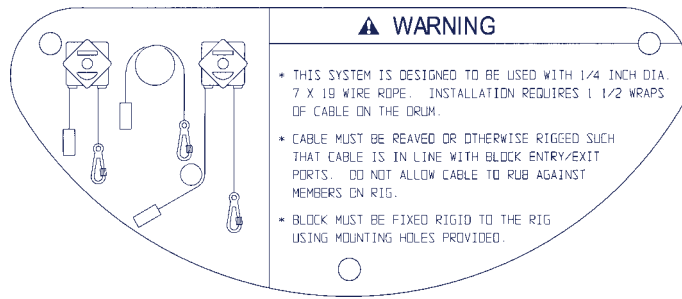

Label - Right Side



Label - Serialized

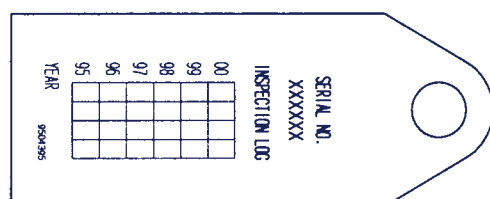
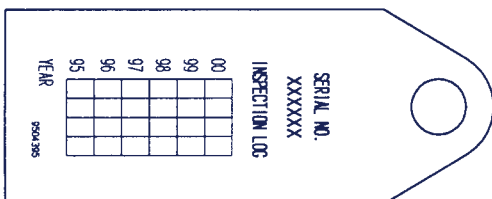
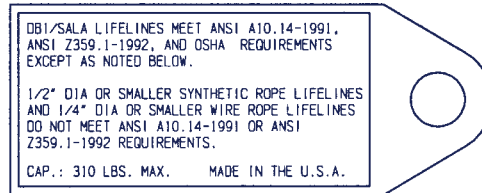
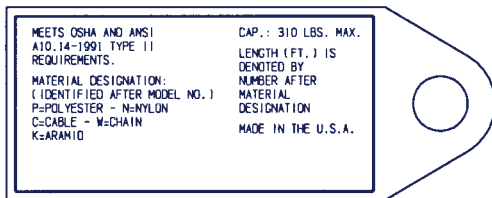

Harness and Rung Hook Assembly Label



Lifeline Label

Safety Block Parts Listing

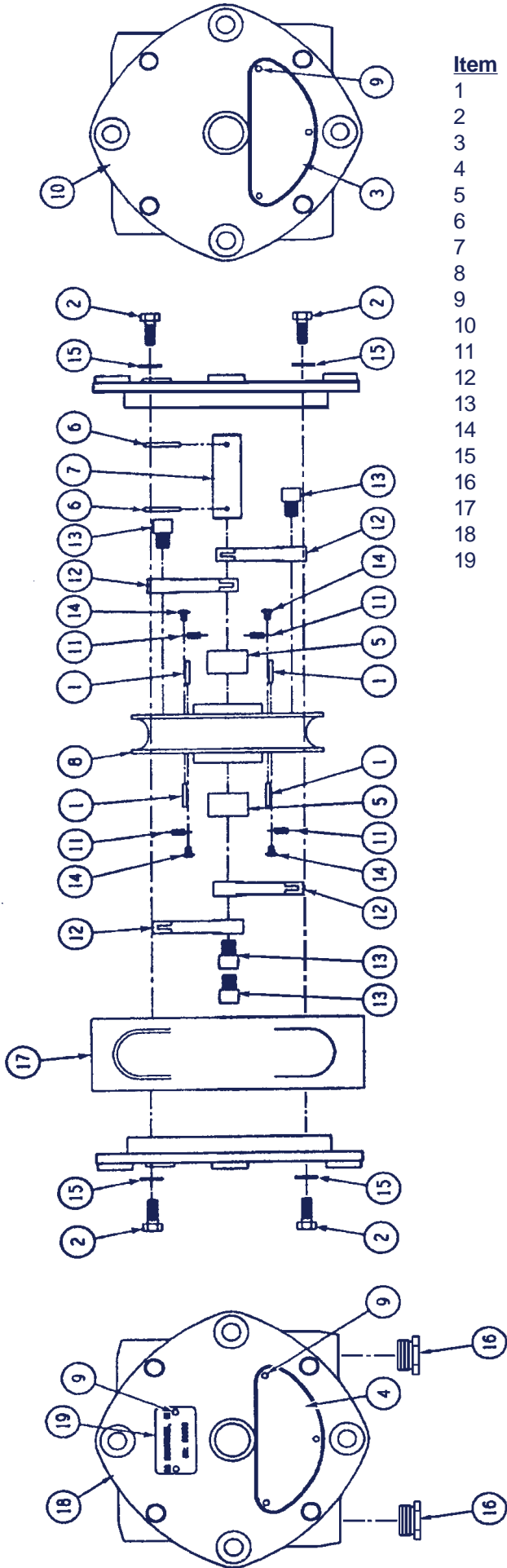

<u>Item</u>	<u>Part No.</u>	<u>Description</u>	<u>Quantity</u>
1	9500309	Pin, Spring, 1/8x3/4, SS	4
2	9503471	Bolt, HH, 5/16-18x3/4, SS	8
3	9501599	Label, Rear	1
4	9501600	Label, Front	1
5	9501642	Bearing, 7/8x10-1/4x3/4 Bronze	2
6	9501643	Pin, Spring, 1/8x1-1/8, SS	2
7	3903007	Shaft	1
8	3903008	Sheave	1
9	9501648	Stud, Drive, .014x3/16, ZP	8
10	9509590	Cover, Rear	1
11	9501715	Spring, 3/16x1x.015, SS	4
12	9501988	Pawl	4
13	3520080	Screw, 7/16-14	4
14	9503015	Screw, Tap, 6-32x3/8, SS	4
15	9503203	Washer, 5/16, ZP	8
16	9508103	Bushing, Plastic	2
17	9509589	Housing	1
18	9510314	Cover, Front	1
19	9503194	Label, Serialized, Front	1

**9.0 INSPECTION AND MAINTENANCE LOG**

DATE OF MANUFACTURE: \_\_\_\_\_

MODEL NUMBER: \_\_\_\_\_

DATE PURCHASED: \_\_\_\_\_

INSPECTION DATE	INSPECTION ITEMS NOTED	CORRECTIVE ACTION	MAINTENANCE PERFORMED
Approved By: _____			
Approved By: _____			
Approved By: _____			
Approved By: _____			
Approved By: _____			
Approved By: _____			
Approved By: _____			
Approved By: _____			
Approved By: _____			
Approved By: _____			
Approved By: _____			

**9.0 INSPECTION AND MAINTENANCE LOG**

DATE OF MANUFACTURE: \_\_\_\_\_

MODEL NUMBER: \_\_\_\_\_

DATE PURCHASED: \_\_\_\_\_

INSPECTION DATE	INSPECTION ITEMS NOTED	CORRECTIVE ACTION	MAINTENANCE PERFORMED
Approved By: _____			
Approved By: _____			
Approved By: _____			
Approved By: _____			
Approved By: _____			
Approved By: _____			
Approved By: _____			
Approved By: _____			
Approved By: _____			
Approved By: _____			
Approved By: _____			
Approved By: _____			
Approved By: _____			

## WARRANTY

Equipment offered by DBI/SALA is warranted against factory defects in workmanship and materials for a period of two years from date of installation or use by the owner, provided that this period shall not exceed two years from date of shipment. Upon notice in writing, DBI/SALA will promptly repair or replace all defective items. DBI/SALA reserves the right to elect to have any defective item returned to its plant for inspection before making a repair or replacement. This warranty does not cover equipment damages resulting from abuse, damage in transit, or other damage beyond the control of DBI/SALA. This warranty applies only to the original purchaser and is the only one applicable to our products, and is in lieu of all other warranties, expressed or implied.



### USA

3965 Pepin Avenue  
Red Wing, MN 55066-1837  
Toll Free: 800-328-6146  
Phone: (651) 388-8282  
Fax: (651) 388-5065  
[www.salagroup.com](http://www.salagroup.com)

### Canada

260 Export Boulevard  
Mississauga, Ontario L5S 1Y9  
Toll Free: 800-387-7484  
Phone: (905) 795-9333  
Fax: (905) 795-8777  
[www.salagroup.com](http://www.salagroup.com)

This manual is available for download at [www.salagroup.com](http://www.salagroup.com).



Form: 5902147  
Rev: D